

Cordless Woven Natural Shade



WARNING

Cords and bead chains can loop around a child's neck and strangle.

- Always keep cords and bead chains out of children's reach.
- Move furniture away from cords and bead chains. Children can climb furniture to get to cords.
- Do not tie cords together. Make sure cords do not twist together and create a loop.

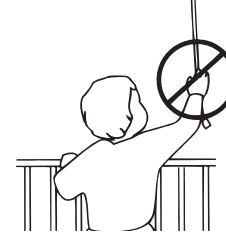

IMPORTANT INFORMATION ABOUT YOUR ROMAN STYLE NATURAL SHADE

This product is designed to make your shade safer for children and pets. However, this shade is substantially different than the traditional shades that you might be accustomed to. This shade has a double cording system on the back of the shade to help minimize the possibility of a child or pet becoming entangled in the cords.

See the operating instructions toward the back of this handbook for additional information about the function of your shade.

Color, Materials and Characteristics:

Your woven natural shade is made with materials harvested from nature. Each harvest of natural fibers is unique and will have variations in color, grain, texture, striations and warping. As a result of these inherent qualities, no two shades are identical, nor can they be. Over time, exposure to light will soften and slightly darken the color of the shade. Small cracks in bamboo slats are natural and unavoidable.

INSTALLATION INSTRUCTIONS

Step 1. Check Package Contents

Missing part? Call 1-800-264-1190

Mounting hardware kit includes the following:

Part	Quantity
Mounting Bracket (includes washer & wing nut)	2 (up to 54" wide) 3 (55" To 72" wide)
1" Screws	4 per bracket

Step 2. Tools Required

Screwdriver, tape measure, pencil, drill, step ladder

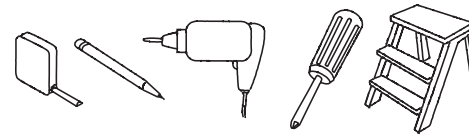

Use a $\frac{3}{32}$ " drill bit to predrill screw holes.
Use a $\frac{1}{4}$ " drill bit for wall anchors.

Step 3. Bracket Location and Installation

Your shade may be installed either inside the window frame or outside the window frame.

For Outside Mounting:

Place a bracket on both ends of the head rail (and one in the center for larger shades). Hold the shade level at the height

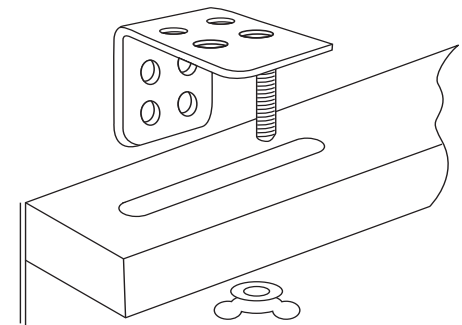
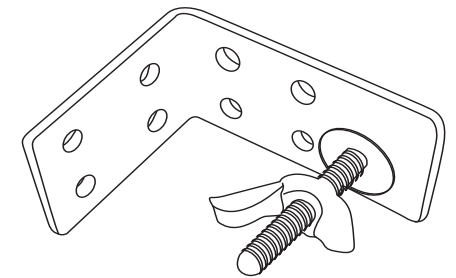

desired and center it over the window opening - mark the exact location of each bracket with a pencil. Remove the brackets from the head rail and position each bracket at the marked location. Mark the location of each screw hole with a pencil.

Predrill the screw holes with a 3/32" drill bit. Screw each bracket into the wall or window molding using the 1" screws.

For Inside Mounting:

Place a bracket on both ends of the head rail (and one in the center for larger shades). Hold the shade in place and make a pencil mark at the rear of each bracket where it contacts the inside of the window frame. Remove the brackets from the head rail and align them with the marks. Mark the location of each screw hole with a pencil. Predrill the screw holes with a 3/32" drill bit. Attach each bracket using the 1" screws.

Step 4. Securing the Head Rail

Lift the head rail into position – place a washer and wing nut on the post of each bracket – tighten by hand.

Step 5. How to Operate

To lower shade: hold the center of the bottom of the shade and pull downward slowly until the shade reaches the desired level.

To lift shade: place your hand (palm facing up) under the bottom of the shade and push upward slowly – if the shade material bunches-up, stop momentarily and then continue pushing upward - do this repeatedly if necessary until the shade reaches the desired height.

IMPORTANT

Always push and pull at the center of the shade to assure that the bottom of the shade remains even (i.e. parallel to the top of the shade).

For wide shades (>48") use two hands, shoulder width apart or wider.

If the shade becomes uneven, slowly pull it all the way down, and then lift to the desired position. If necessary, reach behind the shade and manually pull the cording slowly out of the head rail until the bottom of the shade is level.

CLEANING YOUR SHADES

Use a feather duster or vacuum using the soft brush attachment.

REPLACEMENT PARTS

In the event that replacement parts are ever

needed, you may call: 1-800-264-1190
Please be sure to provide the following information, if possible:

- The complete model or catalog number of your product
- A description of the product
- A description of the part needed

LIMITED LIFETIME WARRANTY

The enclosed product is warranted to the original residential retail purchaser as long as the product remains in the original window.

Covered:

Lifetime: Entire product against manufacturing defects (i.e. a flaw in the product design, materials, or workmanship that causes the product to no longer function)

3 years: Cords including internal cords such as those found in cordless blinds.

5 years: All fabric

Not Covered:

Normal Wear and Tear

Any product that fails due to:

- abuse
- exposure to salt air
- improper installation
- accident
- extraordinary use
- improper operation
- alterations
- improper cleaning
- misapplication
- damage from pests/insects/pets
- improper handling
- misuse

Natural wood products that have:

- loss of color intensity
- yellowing or cracking of plastic parts or foam wood product
- variations in color, grain, or texture
- warping of wood slats in high humidity areas

Costs associated with:

- product removal
- transportation to and from the retailer
- brand label removal
- product remeasure
- incidental or consequential damages
- product reinstallation
- shipping

In the event there are multiple blinds/shades in the same room, only the defective blind/shade will be replaced.

To Report Shipping Damage:

If damage occurred during shipping, call place of purchase and report within 7 calendar days or else you may be denied credit for your damaged product.

To Obtain Service:

If you suspect this product has a manufacturing defect in materials or workmanship:

1. Locate the sales receipt
2. Call place of purchase

Any unauthorized returns will not be accepted.

Warranty Remedy:

THIS SHALL BE YOUR SOLE REMEDY UNDER THIS LIMITED WARRANTY.

If this product is found to have a manufacturing defect in materials or workmanship, we will (at our discretion) do one of the following

- repair the product
- replace the product
- refund the cost of the product

Colors vary from lot to lot and may not exactly match sample swatch or previous purchases. Discontinued items or color selections will be replaced with the closest equivalent current product.

YOUR RIGHTS UNDER STATE LAW:

This lifetime limited warranty gives you specific legal rights, and you may have other rights, which vary from state to state. Some states do not allow limitations on how long a warranty lasts, so the above limitations may not apply to you.

No agent, representative, dealer, or unauthorized employee has the authority to increase or alter the obligation of this warranty. This lifetime limited warranty supersedes any previous versions.

For all questions, please call
(800) 264-1190

Hours of operation are
8:00am to 5:00pm CST

The logo for SelectBlinds, featuring a stylized window blind icon above the brand name "SelectBlinds" in a large, bold, sans-serif font. The "B" in "Blinds" is significantly larger than the other letters.